

Please check the examination details below before entering your candidate information

Candidate surname

Other names

Centre Number

Candidate Number

--	--	--	--	--

--	--	--	--

Pearson Edexcel International Advanced Level

Time 1 hour 45 minutes

Paper
reference

WPH14/01

Physics

International Advanced Level

UNIT 4: Further Mechanics, Fields and Particles

You must have:

Scientific calculator, ruler, protractor

Total Marks

Instructions

- Use **black** ink or ball-point pen.
- **Fill in the boxes** at the top of this page with your name, centre number and candidate number.
- Answer **all** questions.
- Answer the questions in the spaces provided – *there may be more space than you need.*
- **Show all your working out** in calculations and **include units** where appropriate.

Information

- The total mark for this paper is 90.
- The marks for **each** question are shown in brackets – *use this as a guide as to how much time to spend on each question.*
- In the question marked with an **asterisk** (*), marks will be awarded for your ability to structure your answer logically, showing how the points that you make are related or follow on from each other where appropriate.
- The list of data, formulae and relationships is printed at the end of this booklet.

Advice

- Read each question carefully before you start to answer it.
- Try to answer every question.
- Check your answers if you have time at the end.

Turn over ►

P67157A

©2021 Pearson Education Ltd.

E:1/1/1/1/



Pearson

SECTION A

Answer ALL questions.

For questions 1–10, in Section A, select one answer from A to D and put a cross in the box . If you change your mind, put a line through the box and then mark your new answer with a cross .

1 Which of the following is a fundamental particle?

- A atom
- B baryon
- C neutrino
- D pion

(Total for Question 1 = 1 mark)

2 Which row of the table identifies what happens to momentum and kinetic energy in an elastic collision?

	Momentum	Kinetic energy
<input type="checkbox"/> A	conserved	conserved
<input type="checkbox"/> B	conserved	not conserved
<input type="checkbox"/> C	not conserved	conserved
<input type="checkbox"/> D	not conserved	not conserved

(Total for Question 2 = 1 mark)

3 A particle of mass m has kinetic energy E_k and momentum p . A second particle of mass $2m$ has kinetic energy $2E_k$. Both particles are non-relativistic.

Which of the following is equal to the momentum of the second particle?

- A $\sqrt{2}p$
- B p
- C $2p$
- D $4p$

(Total for Question 3 = 1 mark)

DO NOT WRITE IN THIS AREA

DO NOT WRITE IN THIS AREA

DO NOT WRITE IN THIS AREA



- 4 Which of the following graphs shows how the electric field strength E varies with distance r from a positive point charge?

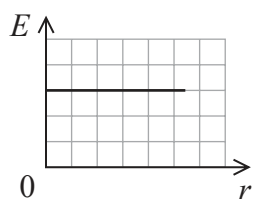

A

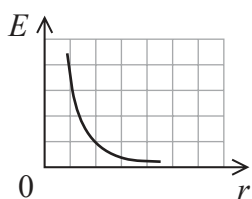

B

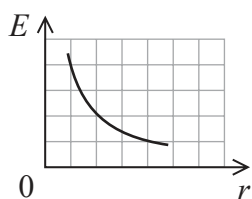

C

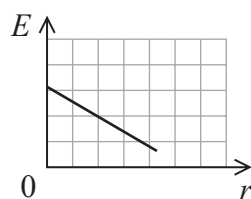

D

- A
- B
- C
- D

(Total for Question 4 = 1 mark)

- 5 The diagram shows a rectangular coil of N turns. The coil rotates around an axis as shown. A magnetic field acts perpendicular to the plane of the coil in the position shown.

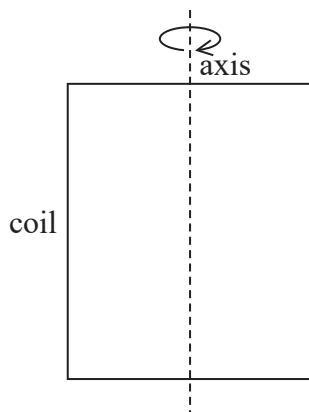

The magnetic flux linkage with the coil is $N\phi$. The coil is rotated through an angle of π radians.

Which of the following is equal to the change in magnetic flux linkage with the coil?

- A 0
- B $N\phi/2$
- C $N\phi$
- D $2N\phi$

(Total for Question 5 = 1 mark)



6 The electric potential V varies with the distance r from a charged object as shown.

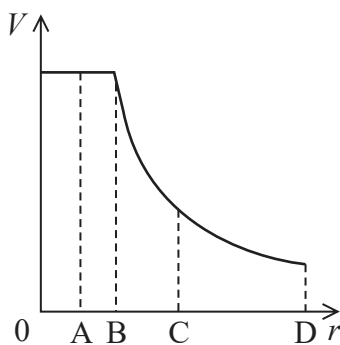

At which distance, A, B, C or D, does the electric field strength have its maximum value?

- A
- B
- C
- D

(Total for Question 6 = 1 mark)

DO NOT WRITE IN THIS AREA

DO NOT WRITE IN THIS AREA

DO NOT WRITE IN THIS AREA



- 7 A battery of e.m.f. V is connected to a capacitor as shown. The capacitor is initially uncharged.

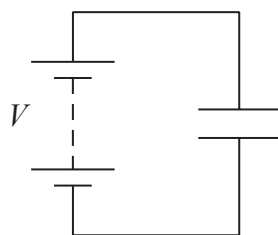

Work is done by the battery to transfer a charge Q from one plate of the capacitor to the other plate. The final potential difference across the capacitor is V .

Which row of the table gives the work done by the battery, and the energy stored by the capacitor, at the end of this process?

	Work done by battery	Energy stored by capacitor
<input type="checkbox"/> A	$\frac{QV}{2}$	$\frac{QV}{2}$
<input type="checkbox"/> B	$\frac{QV}{2}$	QV
<input type="checkbox"/> C	QV	$\frac{QV}{2}$
<input type="checkbox"/> D	QV	QV

(Total for Question 7 = 1 mark)

- 8 Which of the following statements does **not** help to explain why electrons can be used to probe the nuclei of atoms?

- A Electrons can be accelerated to high energies.
- B Electrons can be part of an atom.
- C Electrons can exhibit diffraction effects.
- D Electrons can have wavelengths similar in size to nuclear diameters.

(Total for Question 8 = 1 mark)



9 Which of the following is the quark structure for a π^- particle?

- A d d d
- B $\bar{u} \bar{u} \bar{d}$
- C $\bar{u} d$
- D u d

(Total for Question 9 = 1 mark)

10 The diagram shows a current-carrying wire at an angle θ to a uniform magnetic field.

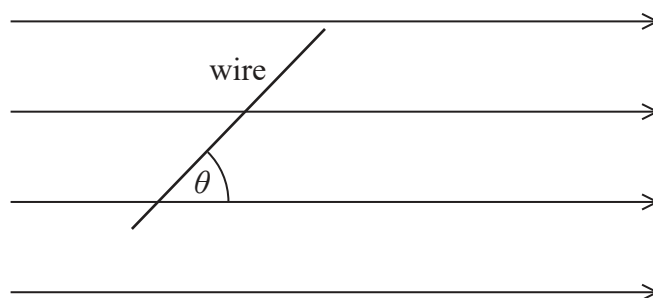

Which of the following graphs shows how the force F on the wire varies as θ is increased from 0 to 90° ?

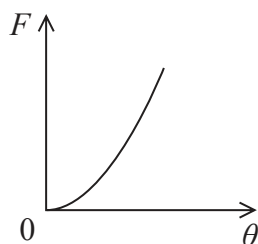

A

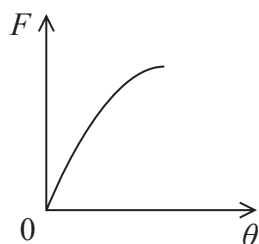

B

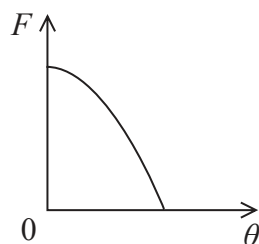

C

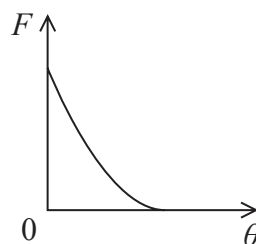

D

(Total for Question 10 = 1 mark)

TOTAL FOR SECTION A = 10 MARKS



SECTION B

Answer ALL questions. Write your answers in the spaces provided.

11 There is an electric field around a helium nucleus.

(a) Calculate the electric potential at a distance 26.6×10^{-12} m from a helium ${}^4_2\text{He}$ nucleus.

(3)

.....

.....

.....

.....

.....

.....

.....

Electric potential =

(b) State one assumption made for this calculation.

(1)

.....

.....

(Total for Question 11 = 4 marks)

DO NOT WRITE IN THIS AREA

DO NOT WRITE IN THIS AREA

DO NOT WRITE IN THIS AREA



P 6 7 1 5 7 A 0 7 2 8

- 12 18th century clocks sometimes used a conical pendulum to measure regular periods of time. A conical pendulum consists of a bob of mass m fixed to the end of a wire of length l as shown. The bob is set to follow a circular path in the horizontal plane. The wire makes an angle θ with the vertical.

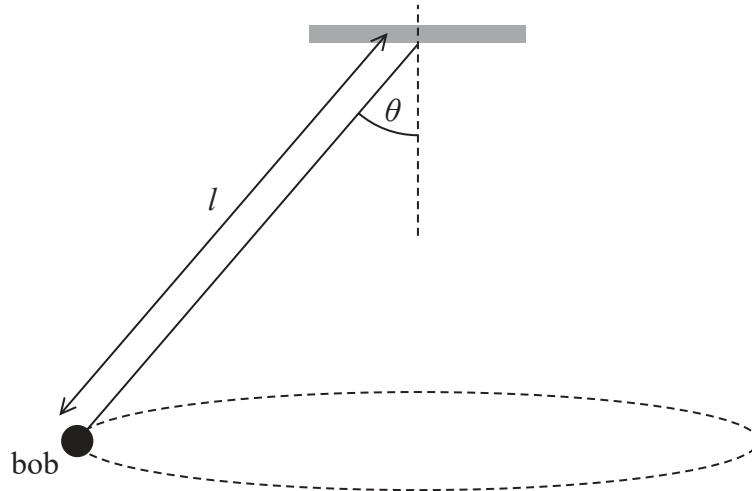

- (a) Add to the diagram to show the two forces acting on the bob.

(2)

- (b) (i) Derive the following equation for the angular velocity ω of the bob.

$$\omega = \sqrt{\frac{g}{l \cos \theta}}$$

(4)



(ii) A clock requires the period of the bob to be 5.0 s.

$$l = 6.4 \text{ m}$$

$$\theta = 13.9^\circ$$

Deduce whether this arrangement leads to the required period.

(3)

.....

.....

.....

.....

.....

.....

.....

(Total for Question 12 = 9 marks)

DO NOT WRITE IN THIS AREA

DO NOT WRITE IN THIS AREA

DO NOT WRITE IN THIS AREA



DO NOT WRITE IN THIS AREA

DO NOT WRITE IN THIS AREA

DO NOT WRITE IN THIS AREA

BLANK PAGE



P 6 7 1 5 7 A 0 1 1 2 8

- 14 The train on a model railway is powered by contact with the rails. The train sometimes loses contact with the rails. The diagram shows a circuit that can maintain power for an electronic controller on the train even when the power is disconnected for a short time. The switch represents the contact between the train and the rails.

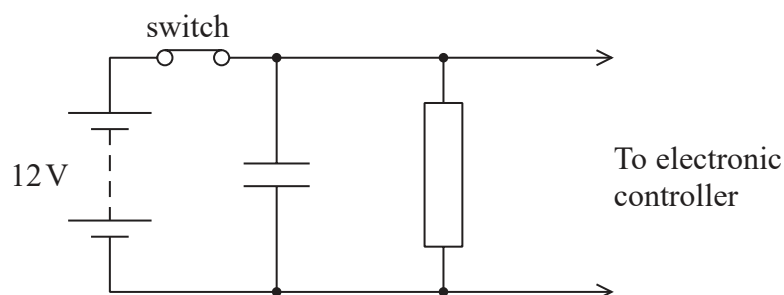

- (a) Explain how this circuit can maintain power to the electronic controller if the switch is opened for a short time.

(3)

.....

.....

.....

.....

.....

.....

- (b) The switch is opened.

Calculate the time taken for the potential difference across the capacitor to decrease to 4.0V.

Assume the resistance of the electronic controller is infinite.

capacitance of capacitor = 47 mF

resistance of resistor = 470 Ω

(2)

.....

.....

.....

.....

Time taken =



DO NOT WRITE IN THIS AREA

DO NOT WRITE IN THIS AREA

DO NOT WRITE IN THIS AREA

(c) The switch is closed at time $t = 0$ and then opened at $t = 20$ s.

Sketch a graph on the axes below to show how current I through the resistor varies with t .

(4)

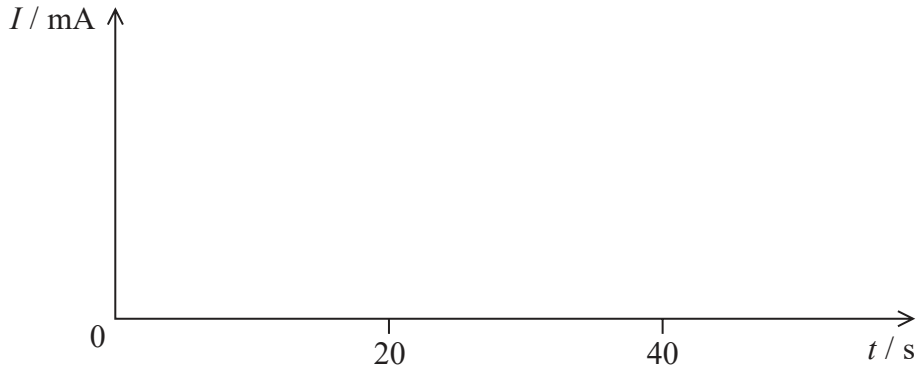

(Total for Question 14 = 9 marks)



P 6 7 1 5 7 A 0 1 3 2 8

- 15 A carriage on a roller coaster ride travels along a horizontal track towards a vertical tower, as shown.

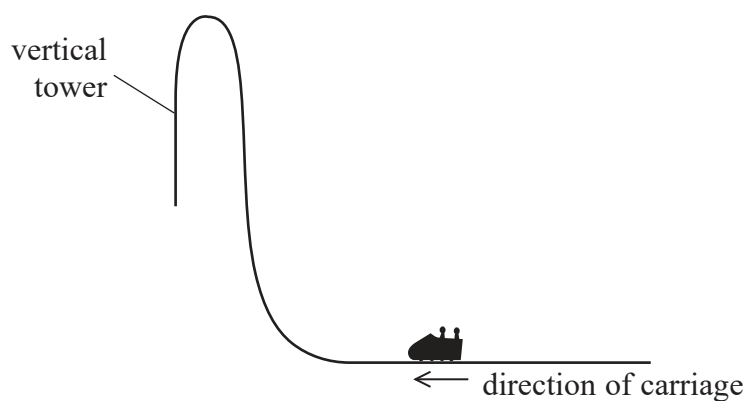

- (a) The carriage starts from rest. A force of 109 kN acts on the carriage for 2.9 s. The carriage then moves up a vertical tower of height 81 m.

- (i) Show that the velocity of the carriage is about 40 m s^{-1} as it leaves the horizontal track.

total mass of carriage and people = 7500 kg

(2)

.....

.....

.....

.....

- (ii) Deduce whether this velocity is enough for the carriage to reach the top of the tower.

Assume that resistive forces are negligible.

(3)

.....

.....

.....

.....

.....



- (b) Just before the carriage reaches the end of the ride it is slowed by an electromagnetic brake. Powerful magnets are attached to the track. An aluminium fin is attached to the carriage. The fin moves through a narrow gap between the magnets.

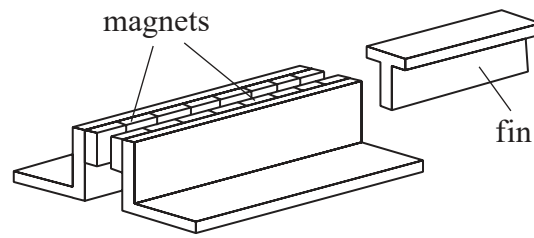

(Source: © MAGNETAR TECHNOLOGIES CORP)

Explain why the fin will leave the gap with a much slower speed than it entered the gap.

(5)

.....

.....

.....

.....

.....

.....

.....

.....

.....

.....

.....

.....

.....

.....

.....

.....

.....

.....

.....

.....

.....

.....

(Total for Question 15 = 10 marks)



- 16 A spark chamber consists of a set of parallel metal plates. It can reveal the path of a high energy particle as shown.



parallel metal plates

(Source: © Smith Collection/Gado/Contributor/Getty Image)

A potential difference of 10.5 kV is applied across two adjacent plates as shown below.



- (a) Sketch lines to represent the electric field between the plates. (3)
- (b) A high energy particle causes ionisation of the atoms in the space between the plates.
- (i) Show that the force on an ionised atom due to the electric field is about $2.6 \times 10^{-13} \text{ N}$.

$$\text{charge on ionised atom} = 1.60 \times 10^{-19} \text{ C}$$

$$\text{distance between plates} = 6.40 \text{ mm}$$

(3)

.....

.....

.....

.....

.....



- (ii) The ionised atom travels $0.2 \mu\text{m}$ in the direction perpendicular to the plates before colliding with another atom.

Deduce whether the collision could lead to further ionisation.

ionisation energy of atoms = $3.9 \times 10^{-19} \text{ J}$

(2)

.....

.....

.....

.....

- (c) Most of the particles detected in the spark chamber are muons. The muons were created in the upper atmosphere. Muons normally have a very short lifetime and should have decayed before they reach the surface of the Earth.

Explain why these muons reach the surface of the Earth.

(3)

.....

.....

.....

.....

.....

.....

.....

(Total for Question 16 = 11 marks)

DO NOT WRITE IN THIS AREA

DO NOT WRITE IN THIS AREA

DO NOT WRITE IN THIS AREA



17 A particle collider can include a LINAC.

(a) The diagram represents a LINAC.

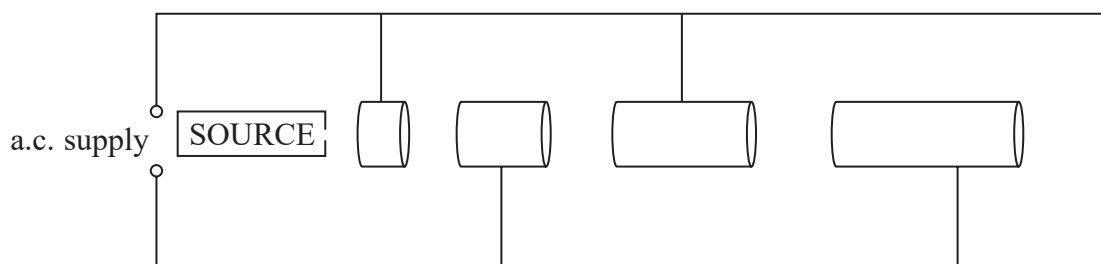

Explain why this arrangement works with a constant frequency a.c. supply.

(4)

.....

.....

.....

.....

.....

.....

.....

.....

.....

.....

(b) In a particle collider, a positron and an electron collided. Each particle had an energy of 14.5 GeV. The collision produced two particles of a type called omega baryons.

(i) An omega baryon has a mass equivalent to 3272 times the mass of an electron.

Show that the mass of an omega baryon is about $1700 \text{ MeV}/c^2$.

(4)

.....

.....

.....

.....

.....

.....

.....

.....

.....

.....



(ii) Calculate the kinetic energy of one of the omega baryons.

(3)

.....

.....

.....

.....

.....

Kinetic energy =

(c) A student correctly suggests that this collision cannot lead to both particles being omega baryons, as this breaks a conservation law.

Discuss the student's suggestion.

(3)

.....

.....

.....

.....

.....

.....

.....

(Total for Question 17 = 14 marks)

DO NOT WRITE IN THIS AREA

DO NOT WRITE IN THIS AREA

DO NOT WRITE IN THIS AREA



18 The diagram shows particle tracks in a detector.

A positive pion decays into an anti-muon at point X.

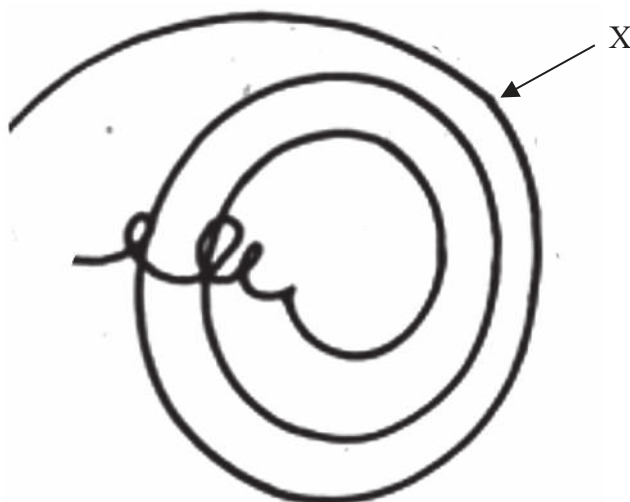

(a) State two ways in which the diagram shows that an anti-muon must also have a positive charge.

(2)

(b) Explain how the diagram shows that the anti-muon is travelling in a clockwise path.

(3)

(c) State the direction of the magnetic field acting in the detector.

(1)



DO NOT WRITE IN THIS AREA

DO NOT WRITE IN THIS AREA

DO NOT WRITE IN THIS AREA

(d) The momentum of the pion is $1.2 \times 10^{-19} \text{ N s}$.

Calculate the radius of the path of the pion.

magnetic flux density = 3.5 T

(3)

Radius =

(e) A neutrino is also produced at X.

(i) Write an equation for this decay process.

(1)



P 6 7 1 5 7 A 0 2 1 2 8

- (ii) The initial path of the muon is at an angle of 18° to the direction of the pion, as shown. Data for the momentum of each particle at point X is listed below.

$$\text{momentum of pion} = 1.2 \times 10^{-19} \text{ N s}$$

$$\text{momentum of muon} = 0.75 \times 10^{-19} \text{ N s}$$

$$\text{momentum of neutrino} = 0.54 \times 10^{-19} \text{ N s}$$

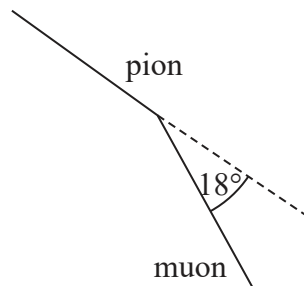

Deduce whether this data is consistent with the law of conservation of momentum. You should include a scaled vector diagram in the space below.

(5)

(Total for Question 18 = 15 marks)

TOTAL FOR SECTION B = 80 MARKS
TOTAL FOR PAPER = 90 MARKS



List of data, formulae and relationships

Acceleration of free fall	$g = 9.81 \text{ m s}^{-2}$	(close to Earth's surface)
Boltzmann constant	$k = 1.38 \times 10^{-23} \text{ J K}^{-1}$	
Coulomb's law constant	$k = 1/4\pi\epsilon_0$ $= 8.99 \times 10^9 \text{ N m}^2 \text{ C}^{-2}$	
Electron charge	$e = -1.60 \times 10^{-19} \text{ C}$	
Electron mass	$m_e = 9.11 \times 10^{-31} \text{ kg}$	
Electronvolt	$1 \text{ eV} = 1.60 \times 10^{-19} \text{ J}$	
Gravitational constant	$G = 6.67 \times 10^{-11} \text{ N m}^2 \text{ kg}^{-2}$	
Gravitational field strength	$g = 9.81 \text{ N kg}^{-1}$	(close to Earth's surface)
Permittivity of free space	$\epsilon_0 = 8.85 \times 10^{-12} \text{ F m}^{-1}$	
Planck constant	$h = 6.63 \times 10^{-34} \text{ J s}$	
Proton mass	$m_p = 1.67 \times 10^{-27} \text{ kg}$	
Speed of light in a vacuum	$c = 3.00 \times 10^8 \text{ m s}^{-1}$	
Stefan-Boltzmann constant	$\sigma = 5.67 \times 10^{-8} \text{ W m}^{-2} \text{ K}^{-4}$	
Unified atomic mass unit	$u = 1.66 \times 10^{-27} \text{ kg}$	

Unit 1

Mechanics

Kinematic equations of motion	$s = \frac{(u + v)t}{2}$
	$v = u + at$
	$s = ut + \frac{1}{2}at^2$
	$v^2 = u^2 + 2as$

Forces	$\Sigma F = ma$
	$g = \frac{F}{m}$
	$W = mg$

Momentum	$p = mv$
----------	----------

Moment of force	moment = Fx
-----------------	---------------

Work and energy	$\Delta W = F\Delta s$
-----------------	------------------------

$$E_k = \frac{1}{2}mv^2$$

$$\Delta E_{\text{grav}} = mg\Delta h$$

Power

$$P = \frac{E}{t}$$

$$P = \frac{W}{t}$$



Efficiency

$$\text{efficiency} = \frac{\text{useful energy output}}{\text{total energy input}}$$

$$\text{efficiency} = \frac{\text{useful power output}}{\text{total power input}}$$

Materials

Density

$$\rho = \frac{m}{V}$$

Stokes' law

$$F = 6\pi\eta rv$$

Hooke's law

$$\Delta F = k\Delta x$$

Elastic strain energy

$$\Delta E_{\text{el}} = \frac{1}{2}F\Delta x$$

Young modulus

$$E = \frac{\sigma}{\varepsilon} \text{ where}$$

$$\text{Stress } \sigma = \frac{F}{A}$$

$$\text{Strain } \varepsilon = \frac{\Delta x}{x}$$

DO NOT WRITE IN THIS AREA

DO NOT WRITE IN THIS AREA

DO NOT WRITE IN THIS AREA



Unit 2

Waves

Wave speed	$v = f\lambda$
Speed of a transverse wave on a string	$v = \sqrt{\frac{T}{\mu}}$
Intensity of radiation	$I = \frac{P}{A}$
Refractive index	$n_1 \sin \theta_1 = n_2 \sin \theta_2$ $n = \frac{c}{v}$
Critical angle	$\sin C = \frac{1}{n}$
Diffraction grating	$n\lambda = d \sin \theta$

Electricity

Potential difference	$V = \frac{W}{Q}$
Resistance	$R = \frac{V}{I}$
Electrical power, energy	$P = VI$ $P = I^2R$ $P = \frac{V^2}{R}$ $W = VIt$
Resistivity	$R = \frac{\rho l}{A}$
Current	$I = \frac{\Delta Q}{\Delta t}$ $I = nqvA$
Resistors in series	$R = R_1 + R_2 + R_3$
Resistors in parallel	$\frac{1}{R} = \frac{1}{R_1} + \frac{1}{R_2} + \frac{1}{R_3}$

Particle nature of light

Photon model	$E = hf$
Einstein's photoelectric equation	$hf = \phi + \frac{1}{2}mv_{\max}^2$
de Broglie wavelength	$\lambda = \frac{h}{p}$



Unit 4*Further mechanics*

Impulse

$$F\Delta t = \Delta p$$

Kinetic energy of a non-relativistic particle

$$E_k = \frac{p^2}{2m}$$

Motion in a circle

$$v = \omega r$$

$$T = \frac{2\pi}{\omega}$$

$$a = \frac{v^2}{r}$$

$$a = r\omega^2$$

Centripetal force

$$F = ma = \frac{mv^2}{r}$$

$$F = mr\omega^2$$

Electric and magnetic fields

Electric field

$$E = \frac{F}{Q}$$

Coulomb's law

$$F = \frac{Q_1 Q_2}{4\pi\epsilon_0 r^2}$$

$$E = \frac{Q}{4\pi\epsilon_0 r^2}$$

$$E = \frac{V}{d}$$

Electrical potential

$$V = \frac{Q}{4\pi\epsilon_0 r}$$

Capacitance

$$C = \frac{Q}{V}$$

Energy stored in capacitor

$$W = \frac{1}{2} QV$$

$$W = \frac{1}{2} CV^2$$

$$W = \frac{1}{2} \frac{Q^2}{C}$$

Capacitor discharge

$$Q = Q_0 e^{-t/RC}$$



Resistor-capacitor discharge

$$I = I_0 e^{-t/RC}$$

$$V = V_0 e^{-t/RC}$$

$$\ln Q = \ln Q_0 - \frac{t}{RC}$$

$$\ln I = \ln I_0 - \frac{t}{RC}$$

$$\ln V = \ln V_0 - \frac{t}{RC}$$

In a magnetic field

$$F = Bqv \sin \theta$$

$$F = BIl \sin \theta$$

Faraday's and Lenz's laws

$$\mathcal{E} = \frac{-d(N\phi)}{dt}$$

Nuclear and particle physics

In a magnetic field

$$r = \frac{p}{BQ}$$

Mass-energy

$$\Delta E = c^2 \Delta m$$

DO NOT WRITE IN THIS AREA

DO NOT WRITE IN THIS AREA

DO NOT WRITE IN THIS AREA



P 6 7 1 5 7 A 0 2 7 2 8

DO NOT WRITE IN THIS AREA

DO NOT WRITE IN THIS AREA

DO NOT WRITE IN THIS AREA

BLANK PAGE

